



**ENVIRONMENTAL**

Zoeller Family of Water Solutions™

3649 Cane Run Road · Louisville, KY 40211-1961

877-244-9340 · Fax: 877-414-4316

www.clarusenvironmental.com

## Fusion® Series Treatment Systems

# INSTALLATION INSTRUCTIONS

Congratulations on the purchase of a Fusion® Series Treatment System. This Clarus Environmental system will provide years of service when installed according to the manufacturer's recommendations.

Please read and review this manual before installing the product, and follow the steps in this manual for proper start-up. Many items

contained herein, when followed correctly, will not only ensure a long and problem-free life for the system, but will also save time and money during installation. Reference CL0301J for the Operation and Maintenance Manual. Should further assistance be necessary, please call Clarus Environmental at 1-877-244-9340.

### Table of Contents

Safety Instructions .....	1
Limited Warranty and Application .....	2
Excavation and Installation .....	2-3
Blower Installation and Placement .....	3-4
Piping Installation, Electrical Connections and Backfilling ....	4
Start Up and Aeration Airflow Adjustment .....	5
Flow and Rate Adjustments.....	6
Blower Timer Setting.....	7

### Owner's Information

Model Number: \_\_\_\_\_ Date Code: \_\_\_\_\_

ZF450                       ZF600                       ZF800

Job Name: \_\_\_\_\_

Distributor: \_\_\_\_\_

Date of Purchase: \_\_\_\_\_ Clarus S/O No.: \_\_\_\_\_

Contractor: \_\_\_\_\_

Date of Installation: \_\_\_\_\_

### Safety Instructions

**TO AVOID SERIOUS OR FATAL PERSONAL INJURY OR MAJOR PROPERTY DAMAGE, READ AND FOLLOW ALL SAFETY INSTRUCTIONS IN THIS MANUAL AND ON THE UNIT.**

**THIS MANUAL IS INTENDED TO ASSIST IN THE INSTALLATION AND OPERATION OF THIS UNIT AND MUST BE KEPT WITH THE SYSTEM.**



This is a **SAFETY ALERT SYMBOL**.

When you see this symbol on the unit or in the manual, look for one of the following signal words and be alert to the potential for personal injury or property damage.

- ▲ DANGER** Warns of hazards that **WILL** cause serious personal injury, death or major property damage.
- ▲ WARNING** Warns of hazards that **CAN** cause serious personal injury, death or major property damage.
- ▲ CAUTION** Warns of hazards that **CAN** cause personal injury or property damage.
- ▲ NOTICE** INDICATES SPECIAL INSTRUCTIONS WHICH ARE VERY IMPORTANT AND MUST BE FOLLOWED.

**THOROUGHLY REVIEW ALL INSTRUCTIONS AND WARNINGS PRIOR TO PERFORMING ANY WORK ON THIS UNIT.**

**MAINTAIN ALL SAFETY DECALS.**

**REFER TO WARRANTY ON PAGE 2.**

*The Fusion® Series Treatment Systems represent a collaboration with Fuji Clean Co., Ltd.*

## LIMITED WARRANTY

Manufacturer warrants, to the purchaser and subsequent owner during the warranty period, every new product to be free from defects in material and workmanship under normal use and service, when properly used and maintained, for a period of two years from date of installation. Parts that fail within the warranty period, two years from date of installation, that inspections determine to be defective in material or workmanship, will be repaired, replaced or remanufactured at manufacturer's option, provided however, that by so doing we will not be obligated to replace an entire assembly, the entire mechanism or the complete unit. No allowance will be made for shipping charges, damages, labor or other charges that may occur due to product failure, repair or replacement.

This warranty does not apply to and there shall be no warranty for any material or product that has been disassembled without prior approval of manufacturer, subjected to misuse, misapplication, neglect, alteration, accident or act of God; that has not been installed, operated or maintained in accordance with manufacturer's installation instructions; that has been exposed to outside substances including but not limited to the following: sand, gravel, cement, mud, tar, hydrocarbons, hydrocarbon derivatives (oil, gasoline, solvents, etc.), or other abrasive or corrosive substances, wash towels or feminine sanitary products, etc. in all applications other than in raw sewage pumping applications. The warranty set out in the paragraph above is in lieu of all other warranties expressed or implied;

and we do not authorize any representative or other person to assume for us any other liability in connection with our products.

Contact manufacturer at, 3649 Cane Run Road, Louisville, Kentucky 40211, Attention: Customer Service Department to obtain any needed repair or replacement of part(s) or additional information pertaining to our warranty.

**MANUFACTURER EXPRESSLY DISCLAIMS LIABILITY FOR SPECIAL, CONSEQUENTIAL OR INCIDENTAL DAMAGES OR BREACH OF EXPRESSED OR IMPLIED WARRANTY; AND ANY IMPLIED WARRANTY OF FITNESS FOR A PARTICULAR PURPOSE AND OF MERCHANTABILITY SHALL BE LIMITED TO THE DURATION OF THE EXPRESSED WARRANTY.**

Some states do not allow limitations on the duration of an implied warranty, so the above limitation may not apply to you. Some states do not allow the exclusion or limitation of incidental or consequential damages, so the above limitation or exclusion may not apply to you.

This warranty gives you specific legal rights and you may also have other rights which vary from state to state.

## EXCAVATION AND INSTALLATION

1. Excavate an area large enough for the Fusion® Series unit to be installed. See Figure 1 for the actual dimensions of the unit. Excavation dimensions are calculated by adding 12-18 inches to the length and width of the Fusion®. This will allow sufficient room for proper backfilling.
2. Construct a 6 inch thick stone pad (1/4 - 1/2 inch diameter stone) or concrete pad and level to within 1/8 inch.
3. **▲ NOTICE** If the unit is not level, it will cause uneven water flow as well as unbalanced aeration, which will result in poor performance.
4. Gently lift the unit at all four lifting points with a harness and install it on leveled stone pad (Figure 2).
5. Check unit to make certain it is level by placing a level on several locations of the black riser adapter rings (riser covers removed) (Figure 2).

# EXCAVATION AND INSTALLATION, *cont.*

Figure 1, Dimensions

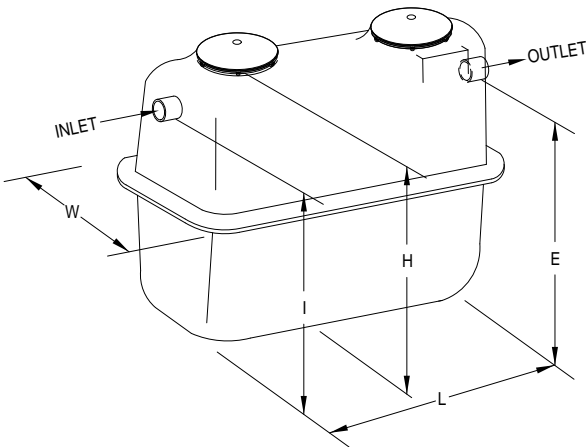

**NOTES:**

- 1) DIMENSIONS "I" AND "E" ARE TO THE BOTTOM OF THE INLET/OUTLET PIPE.
- 2) THE OVERALL HEIGHT DIMENSION "H" IS TO THE TOP OF THE NARROW ADAPTER RING, NOT THE RISER LID.
- 3) A RISER COVER COMES STANDARD. ADDITIONAL RISERS ARE PURCHASED SEPERATELY.

SK2624

Figure 2, Positioning

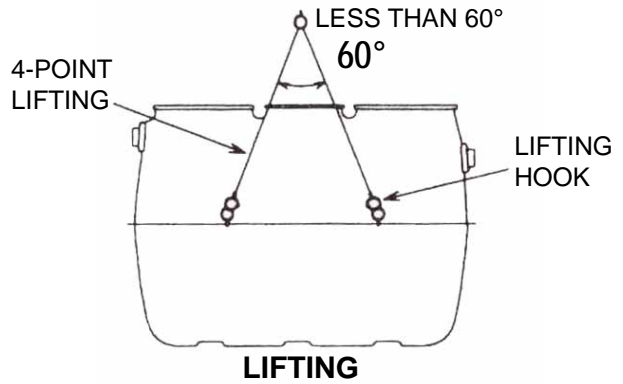

LEVEL ACROSS TOP OF UNIT

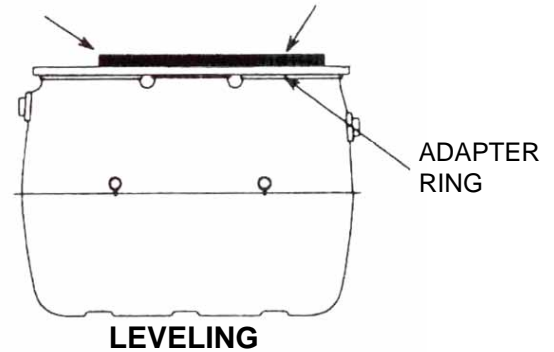

Table 1.

Fusion® DIMENSIONS					
SYSTEM	L	W	H	I	E
Fusion® 450	7'-1"	3'-8"	5'-2"	4'-4"	3'-10"
Fusion® 600	8'	4'-1"	5'-6"	4'-8"	4'-2"
Fusion® 800	8'-3"	4'-8"	6'-2"	5'-4"	4'-10"

## BLOWER INSTALLATION AND PLACEMENT

1. This product must be connected to a grounded, metallic, permanent wiring system, or an equipment-grounding terminal or lead on the product.
2. Place the blower where it is easily accessible for maintenance and inspection.
3. Install the blower in an area where it will be protected from damage and inundation. Also make certain the location has good ventilation.
4. Install the blower on a foundation that is level.
5. Excavate trenches for two air lines from blower to the unit.
6. Install two separate 1/2 inch air lines from the blower to the unit. Length of piping must be less than 17 feet. If distances from 17 feet to 33 feet are required, use 3/4 inch diameter piping (Figure 3).
7. The blower is provided with two discharge ports. They are color coded so that the aeration outlet port is BLUE and the backwash outlet port is RED (Figure 3).
8. The air port inlets on the unit are also color coded, BLUE for aeration and RED for backwash (Figure 3).
9. Attach the barbed end of each PVC tee to the blower using the rubber elbows.
10. Attach small diameter black air tubing to barbed fitting on PVC tee. Black air tubing and blower cord should be routed to the control panel through conduit. Attach the two black air tubing lines to the two air pressure sensor barbed fittings.
11. Connect the remaining end of each PVC tee to the airlines installed in Step 6.

# BLOWER INSTALLATION AND PLACEMENT, *cont.*

Figure 3

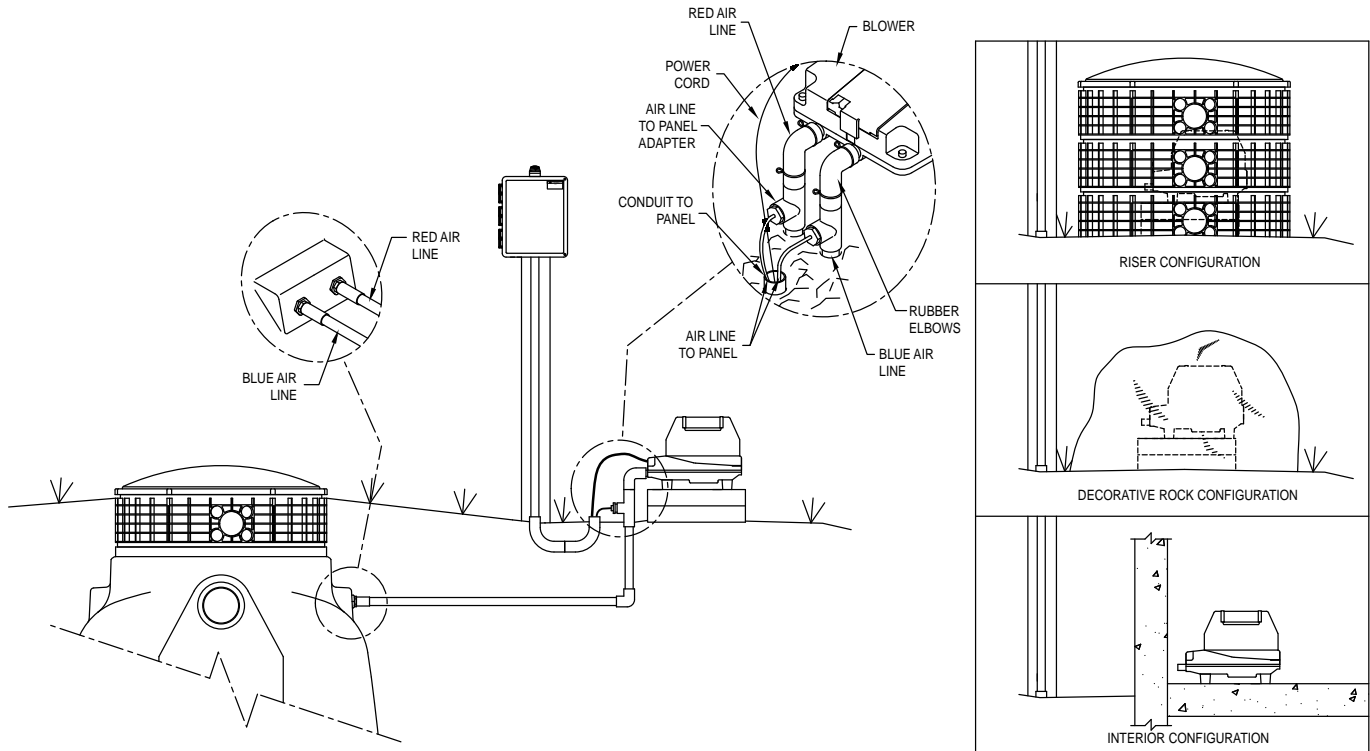

SK2639

## PIPING INSTALLATION

1. Connect house sewer pipe or septic tank outlet, if required, to the unit inlet. Make certain only household waste enters the unit (no foundation drains, gutter drains, etc.).
2. Connect the outlet pipe to the outlet of the unit.

## ELECTRICAL CONNECTIONS

1. **▲ NOTICE** All electrical installations must follow the National Electrical Code and/or your local/state electrical codes.
2. The blower should be directly wired into the alarm panel. The alarm panel must be located in a dry location that is accessible for maintenance. Please see the wiring diagram and instructions enclosed with the alarm panel.

## BACKFILLING

1. If groundwater is present, anti-flotation measures must be used to stabilize the unit prior to backfilling. Use of the four (4) lifting hooks on each side of the unit is permissible for anchoring locations.
2. Fill the unit with clean water to the normal operating depth prior to backfilling. Check for leakage around the unit.
3. If necessary, install riser extensions on the adapter rings prior to backfilling. Make certain risers are sealed properly and watertight.
4. Install riser covers.
5. Backfill with good quality granular soil around the unit that is free of organic matter, rock, stone, tree roots, or other debris that could damage the unit.
6. Tamp soil around perimeter of the unit as it is backfilled to stabilize the unit and to reduce settling.
7. Finalize backfill with a mounded contour so that surface water is shed away from the unit. Under no circumstances should surface water be allowed to accumulate around unit.
8. **▲ CAUTION** MAXIMUM soil burial depth over the unit is 36 inches.

# START UP

1. Verify the unit is installed correctly and that each part functions properly.
2. Verify the unit is filled with water.
3. Verify the blower is on and operating properly.

## AERATION AIRFLOW ADJUSTMENT

There are two aeration systems provided within the aeration chamber; normal aeration and backwash. Normally valves (1 and 3) are set at 50%. Observe the air flow on each side of the unit to verify equal flow. If there is an obvious discrepancy in air flow between the two sides, adjust the valves (1 and 3) so that the flow is equal.

Figure 4, Aeration Flow Adjustment

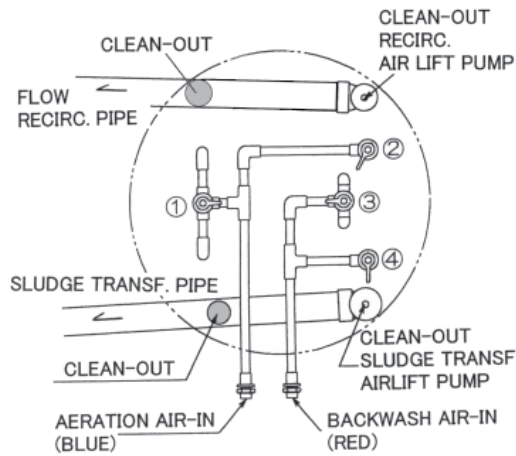

Valve legend:

- |                  |      |                  |                    |      |                  |
|------------------|------|------------------|--------------------|------|------------------|
| 1. Aeration      | Blue | Balance Aeration | 3. Backwash        | Red  | Balance Backwash |
| 2. Recirculation | Gray | See Table 2      | 4. Sludge transfer | Gray | See Table 3      |

Table 2, Recirculation Flow Rates

Model	ZF450	ZF600	ZF800
Recirculating flow rate (GPM)	0.37-0.55	0.50-0.77	0.74-1.11
Recirculating flow rate (sec/liter)	29-45	21-32	14-22
Suggested Valve Opening	35-40%	30-35%	30-35%

Table 3, Backwash Flow Rate Setting

Model	Frequency	ZF450	ZF600	ZF800
Backwash flow rate (GPM)	Twice/day	1.6-2.4	2.1-2.9	2.6-4.0
Backwash flow rate (sec/liter)	Twice/day	7-10	5-7	4-6
Valve open (%)	Twice/day	50-55	40-45	40-45

Figure 5, Flow Measurement

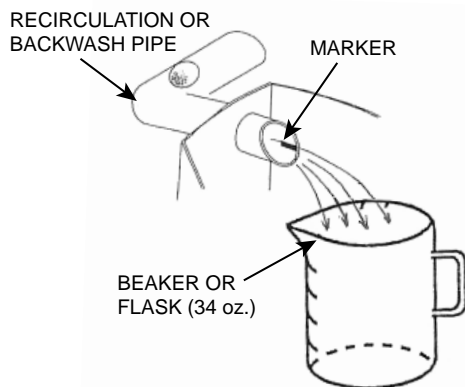
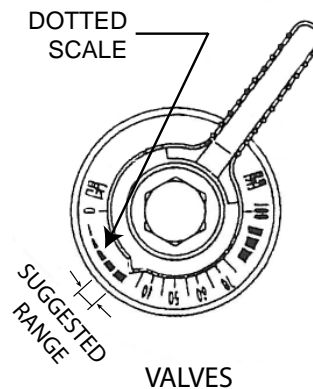

Figure 6, Flow Controlling Valve.



## RECIRCULATION FLOW ADJUSTMENT

The recirculation flow is designed to be 1.2-1.8 times that of the inflow. Table 2 indicates approximate flow rates for each unit. However, fine adjustments may be necessary to ensure optimum performance.

### Setting the flow rate:

- Adjust the flow using rates in Table 2.
- The flow rate is adjusted by rotating the gray recirculation valve (2) and observing the flow at the pipe end.
- There are prescribed lines at the outlet of the recirculation pipe to aid in approximating the correct flow.

### Measuring the flow rate:

- The actual flow rates must be measured to verify flow after adjustment of the valve and observation at the pipe end.
- Measure the time in seconds required to fill a 1000 mL container.
- Compare the time to value ranges in Table 2.
- If necessary, adjust the valve again and collect another sample to verify the correct flow rates.

**NOTE:** It is important not to set the flow rate too high because it can cause excessive agitation within the first chamber (Sedimentation Chamber). This could result in poor performance.

## BACKWASH FLOW ADJUSTMENT

In order to prevent plugging in the Aeration Chamber, the backwash cycle activates at a preset schedule. If there is no backwash cycle or too short of a backwash cycle, the unit's performance will be adversely affected. Likewise, if the backwash cycle is too long, performance will be compromised.

Typically, the backwash cycle begins at 2:00 AM and lasts for five minutes. One hour later, another five minute backwash cycle occurs.

Even with these default settings, the waste water inflow could be too low or too high to optimize the performance and therefore, must be checked during each inspection.

The backwash cycle and sludge transfer from the Aeration chamber takes place at the same time. Verify that the air flow is uniform across the Aeration chamber between the two sides during a backwash cycle. If not, adjust the red backwash valve (3) accordingly.

### Setting the flow rate:

Switch to a manual backwash cycle by pressing the pink "Manual Backwash" button on the blower control pad.

Set the backwash flow rate by adjusting the gray sludge transfer valve (4). Use Table 3 to determine the typical setting for each Fusion® model.

### Measuring the flow rate:

Measure the actual backwash flow rate at the outlet of the sludge return pipe in the first chamber the same way the recirculation flow rate is measured.

Adjust the gray sludge transfer valve (4) if necessary to obtain the proper flows.

Return the blower to normal aeration mode by pressing the pink button on the control pad.

# BLOWER TIMER SETTING

Figure 7

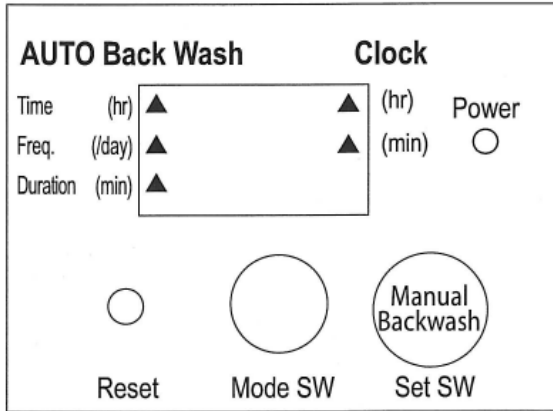

Reset (factory default settings):

1. Press Reset.  
Clock is set to 0.00.  
Backwash Time is set to 2:00 AM.  
Backwash Frequency is set to 2 per day.  
Backwash Duration is set to 5 mins.

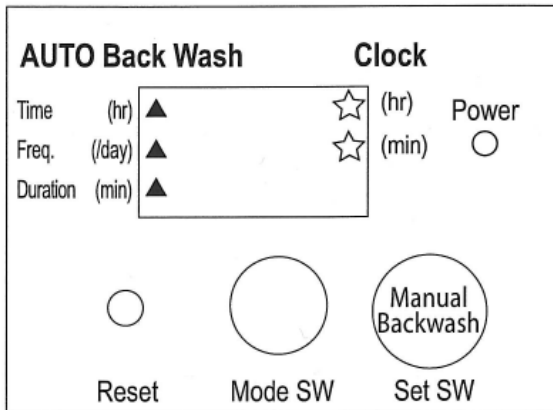

Clock Setting:

1. Press Mode SW to adjust time (hrs).
2. Press Set SW.
3. Press Mode SW to adjust time (mins).
4. Press Set SW.

NOTE: 24 hr clock used.

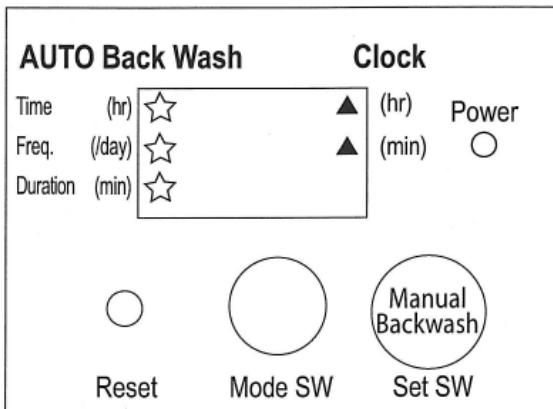

Backwash Time Setting:

1. Press Mode SW to adjust time (hrs).
2. Press Set SW.
3. Press Mode SW to adjust frequency.
4. Press Set SW to 1 or 2.
5. Press Mode SW to adjust duration (mins).
6. Press Set SW to 5 or 10.

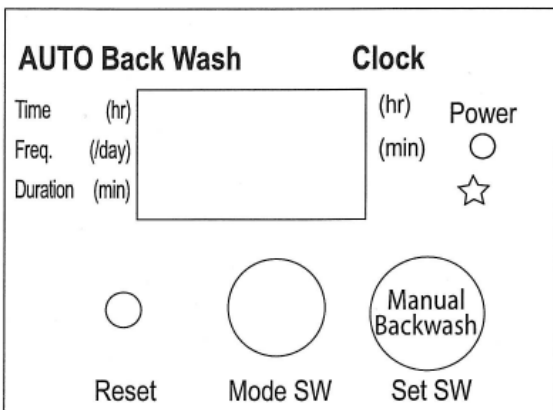

Manual Backwash:

1. Press Set SW during normal operation.
2. Press Set SW again to return to normal operation.

Blower Timer Setting

# NOTES

All Clarus Environmental products must be installed and maintained in accordance with all applicable codes.  
Product information presented here reflects conditions at time of publication. Consult factory regarding discrepancies or inconsistencies.