



ENVIRONMENTAL

Zoeller Family of Water Solutions™

3649 Cane Run Road · Louisville, KY 40211-1961

877-244-9340 · Fax: 877-414-4316

www.clarusenvironmental.com

Fusion® Series Treatment Systems

OWNER'S MANUAL

For use with Models ZF-450, ZF-600 and ZF-800

Owner's Name _____

Address _____

Phone Number _____

Manufacturer's Name **Clarus Environmental**

Manufacturer's Phone Number **877-244-9340**

Fusion® Model: ZF-450 ZF-600 ZF-800

Serial No. _____

Installing Contractor _____

Phone Number _____

Installation Date _____

Maintenance Provider's Name _____

Phone Number _____

Thank you for choosing a Fusion® Series Wastewater Treatment System. High quality workmanship and easy maintenance has been incorporated into the Fusion® system. The system will provide years of trouble-free service when maintained according to the manufacturer's recommendations. Please read this manual in its entirety before using the Fusion® and follow all instructions to ensure proper operation. Keep this manual for future reference along with other important onsite documents. Should further assistance be necessary, please contact Clarus Environmental at 1-877-244-9340.

Warning Labels

You will find warning labels on the Fusion®, riser lids, blower, and the alarm control panel. It is very important to follow the information on these labels to ensure your safety. Please do not remove these labels.



WARNING

SEE BELOW FOR LIST OF WARNINGS

1. DO NOT attempt to service the Fusion® unit yourself. Contact your authorized maintenance provider for all service related issues.
2. There are buried electrical cables and piping near and around the Fusion®. Please consult with your authorized maintenance provider to locate these utilities before excavation.
3. DO NOT bury or cover the Fusion® lids with soil or other debris. This is necessary to allow access for operation and maintenance of the unit.
4. The Fusion® blower must be unobstructed and vented for proper operation. Care must be taken that no grass clippings or other materials accumulate on or around the blower and block ventilation.
5. DO NOT place heavy objects over the Fusion® or drive heavy equipment over the Fusion®, as damage may occur. Damage of this kind is not covered by the warranty.
6. DO NOT plant trees within 15 feet of the Fusion®.

The Fusion® Series Treatment Systems represent a collaboration with Fuji Clean Co., Ltd.

HOW A Fusion® SERIES TREATMENT SYSTEM WORKS

The Fusion® is simple in design, yet very advanced in its wastewater treatment ability. Its design has been refined over many years of intense research and development in order to provide a superior treatment system. Compared to traditional septic tank treatment, the Fusion® will treat wastewater 90-95% more effectively. This high degree of treatment helps to protect both the environment and the health of your family.

The Fusion® utilizes a combination of anaerobic (without oxygen) and aerobic (with oxygen) biological processes to treat wastewater. As wastewater enters the Fusion®, it

is broken down and becomes food for biological processes operating within the unit. The first chamber serves to separate grease and large solids from the liquid. In the second chamber, plastic media with large surface areas are used to greatly increase the populations of beneficial bacteria to optimize treatment. A small linear air blower is used to add air (oxygen) into the third chamber for the aerobic process. The final effluent leaving the system will have been treated to secondary quality effluent and will average less than 10 mg/L CBOD5 and 15 mg/L TSS.

The following description will help you to better understand the process:

Figure 1

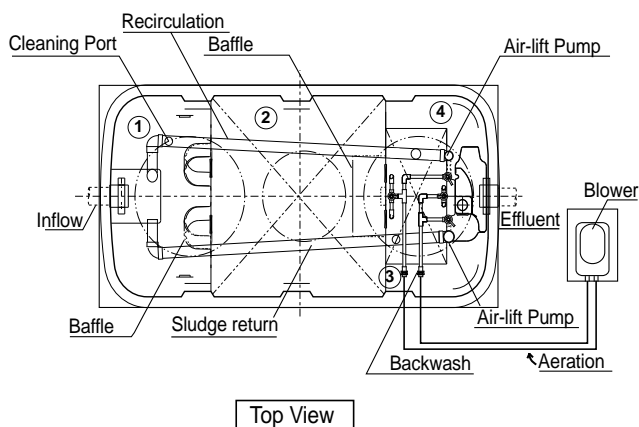
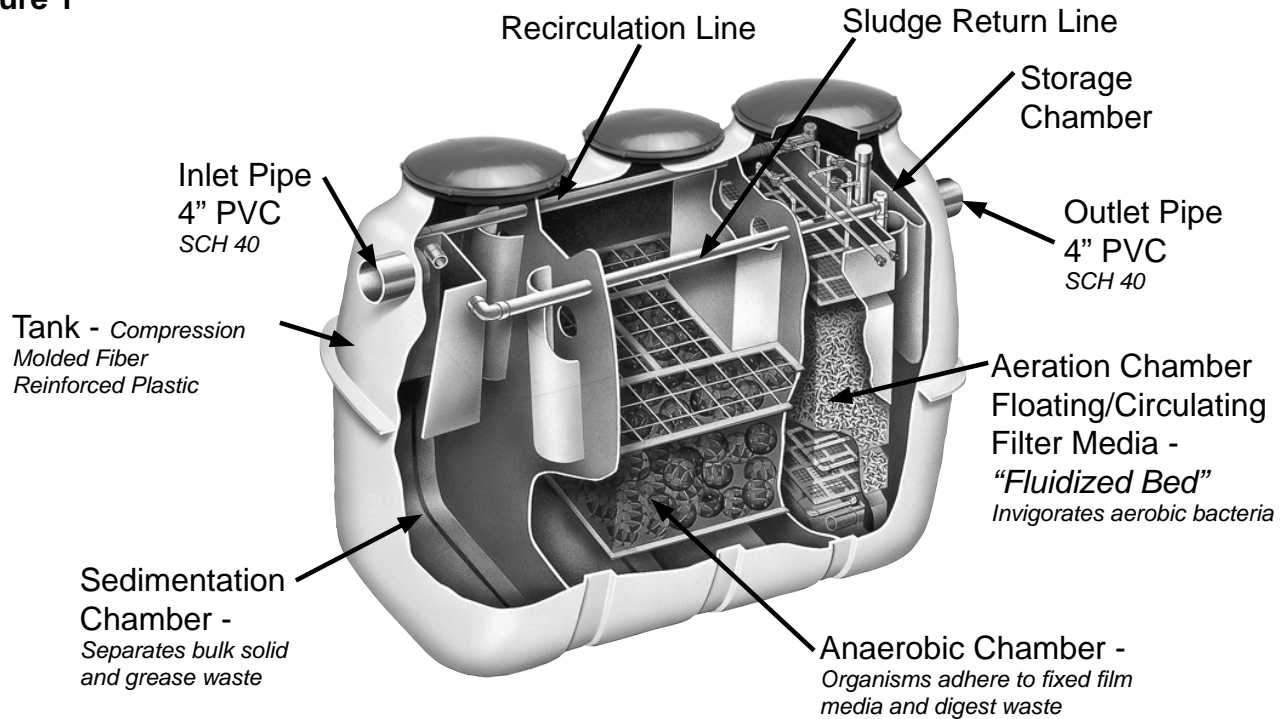

Top View

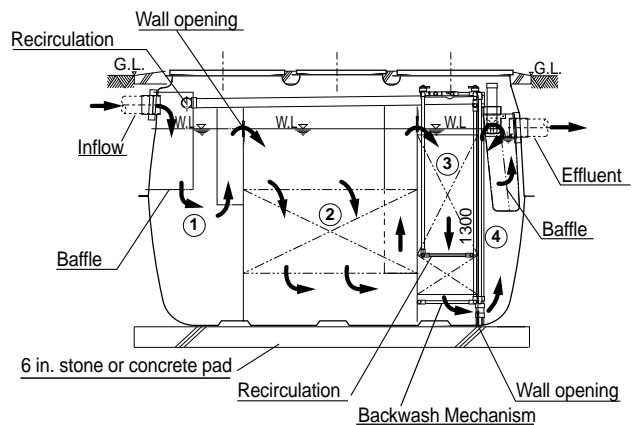

Side View

Figure 2 - Schematic diagram of the Fusion® System.

Figure 3
Treatment Flow of the
Fusion® System.

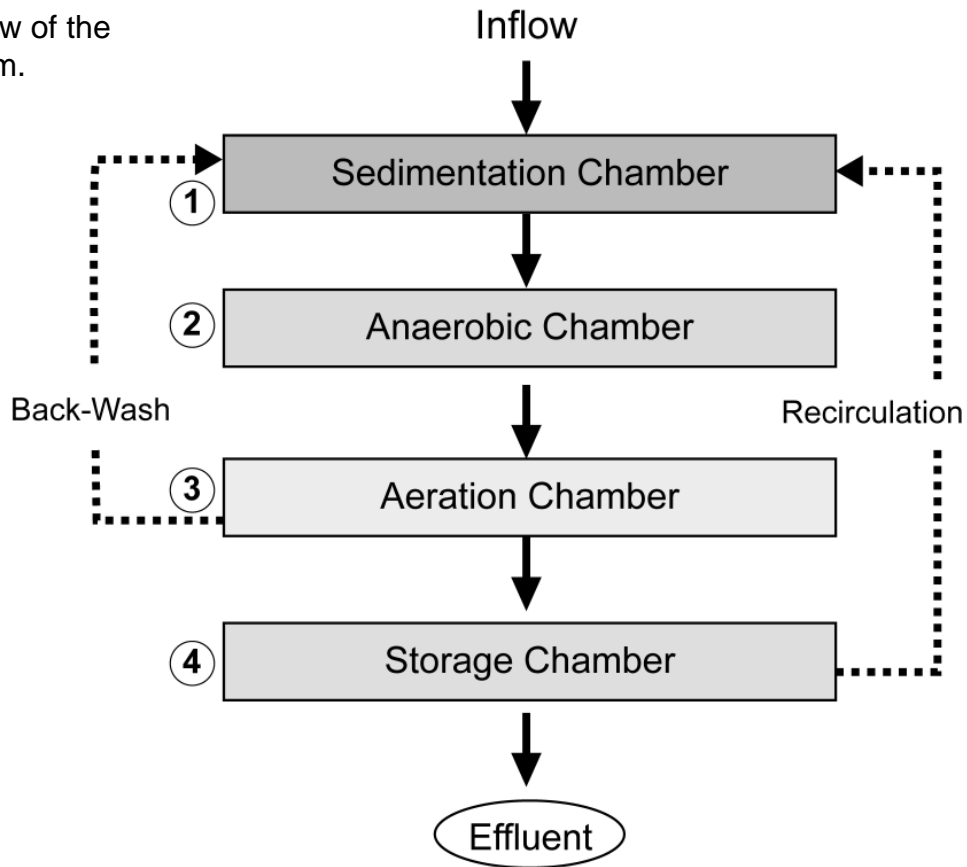

PROCESS DESCRIPTION

1. Sedimentation Chamber

This chamber is designed to physically separate solids and scum from the incoming water.

2. Anaerobic Chamber

This chamber contains a spherical-skeleton type of filter media (4.3 inch diameter). Through bacterial growth processes on the surface of the filter media, biological anaerobic treatment thrives while suspended solids are captured. Furthermore, the microorganisms/bacteria in this chamber convert nitrates in the recirculated water returning from the aerobic chamber to gaseous nitrogen. The nitrogen then escapes to the atmosphere.

3. Aeration Chamber

The aeration chamber consists of an aeration upper section and a filter media lower section. The chamber is filled with hollow, cylindrical filter media (0.6 inch diameter and 0.55 inches long). Biological treatment takes place on the

filter media surface. Aeration is continuous. Residual suspended solids are captured by the filter media circulating in this section. During normal operation, a recirculation line transfers water back to the sedimentation chamber by way of an air lift pump.

The filter media in the aeration chamber are backwashed regularly (twice a day, 5 or 10 minute cycle) by the backwash system located at the bottom of the chamber. The accumulated sludge is transferred by an air lift pump back into the sedimentation chamber for further digestion.

4. Storage Chamber

This chamber is designed to temporarily store treated water exiting the aeration chamber. This treated water is ready for discharge.

SYSTEM COMPONENTS

The complete wastewater treatment system will typically consist of the Fusion® treatment component and a soil absorption field for final disposal of the liquid effluent. Some states or counties may require the addition of a septic tank before the Fusion® to increase the sedimentation chamber capacity and retain more solids. Please see Figure 7 for a typical Fusion® system. Variations to the typical system will be made to suit your particular site and system design needs. Please contact your authorized Fusion® installer or maintenance provider for further information about your system design.

CONTROL PANEL

The Fusion® comes with an alarm panel (see Figure 4) that is designed to activate an audible buzzer and red beacon light on top of the panel if the blower stops producing air pressure or if a high water alarm condition occurs in the Fusion® (Note: Alarm can only function as long as there is electrical power supplied to the panel).

If the alarm sounds or red light comes on, check the air intake area around the blower and make sure no debris blocks the ventilation area. Do not attempt to remove the blower housing or any other parts from the blower. If the blower is operating properly, there may be a high water condition within the Fusion®. It may be necessary to discontinue water use until the alarm condition has been resolved. If the buzzer continues to sound or the red light stays on, please contact your authorized Fusion® maintenance provider immediately. The buzzer may be silenced by toggling the black switch on the side of the alarm panel to “silence”. The red beacon light will remain on until the problem has been resolved.

Check the circuit breaker and make sure the blower circuit is on. Reset the breaker switch if it has been tripped. If it continues to trip or the alarm remains on, contact your Fusion® maintenance provider.

You may from time to time check the proper operation of the alarm panel by toggling the black switch on the side of the panel to “test”. The buzzer will sound and the red beacon will light as long as you hold the switch in the test position. Release the switch for normal operation.

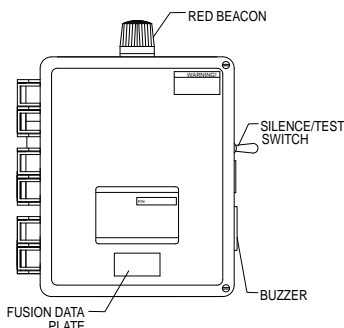

Figure 4

sk2649

IDENTIFICATION PLATE

An identification plate similar to the one in Figure 5 is located on the blower housing and the control panel. There is important information about the Fusion® on the identification plate, such as the part number, model number, serial number, and hydraulic capacity. Please make a note of this information for future reference or in case you should need to contact your Fusion® maintenance provider.

FUSION TREATMENT SYSTEM

- ZF 450 450 GALLONS/DAY
- ZF 600 600 GALLONS/DAY
- ZF 800 800 GALLONS/DAY



Certified to
ANSI-NSF40
Class I
performance
designation

MFG. DATE : 09/07

Manufacturer:
Clarus Environmental • 3649 Cane Run Road
Louisville, KY 40211 • 1-877-244-9340 toll free



BLOWER SERVICE PARTS

- COMPLETE BLOWER: P/N 5250-0005-C
- BLOWER DIAPHRAGM: P/N 018848-A
- BLOWER FILTER: P/N 018849-A

P/N 018860-B

NSF STANDARD 40, Class I, CERTIFICATION MARK

The NSF mark displayed below will be on all NSF Standard 40, Class I certified Fusion® systems. The Fusion® models ZF-450, ZF-600 and ZF-800 will have the mark displayed on the control panel. Systems not NSF Standard 40, Class I certified, will not display the mark.



Certified to
ANSI-NSF40
Class I
performance
designation

Figure 6

HARMFUL & NOT RECOMMENDED HOUSEHOLD SUBSTANCES

The Fusion® is designed to treat household type waste and can treat most common substances introduced into the system. However, certain harmful substances may reduce the efficiency or stop the treatment process by reducing or destroying the beneficial bacterial populations responsible for treatment. In general, if a substance is considered harmful to humans then it should also be considered harmful to the Fusion® treatment system. If you have any questions concerning the use of any of these substances, please contact your Fusion® maintenance provider. **The introduction of any substance on the "Do Not List" into the Fusion® will void the warranty.**

- THE DO NOT LIST -

DO NOT introduce the following substances into the Fusion® treatment system:

- Motor oil
- Brake fluid
- Paint thinner
- Solvents
- Herbicides
- Strong caustic drain cleaners in excess
- Disposing of excess drugs
- Antifreeze
- Paint
- Gasoline
- Pesticides
- Strong disinfectants
- Every Flush toilet disinfection chemicals
- Chemicals & chemical waste

Not Recommended: Trash and excess food products will likely increase frequency of pumping.

Trash

- Sanitary napkins and feminine products
- Diapers
- Paper products such as paper towels and baby wipes
- Plastic/rubber products
- Condoms
- Cat litter
- Dental Floss
- Cigarette butts

Food Products

- Coffee filters and grounds
- Fruit and vegetable peels
- Meat products
- Garbage disposal waste
- Greases or lards
- Seeds
- Bones
- Egg shells

Limited Use Products

Certain products in small or moderate amounts should not disrupt the Fusion® treatment process. You should always follow the minimum quantities of these substances as recommended by the manufacturer.

1. Liquid laundry bleach only as needed per load
2. Liquid laundry detergents without added bleach
3. Liquid dishwashing detergents
4. Household cleaners in moderation

WATER SOFTENERS

Clarus Environmental recommends the use of water and salt conservative softener systems that are installed and operated correctly. If you have questions about softeners, contact the Water Quality Association at www.wqa.org. Contact factory for installation details.

LEAKY FIXTURES

It is very important to monitor all water fixtures in the home for leaks and drips and repair them immediately. Excessive water use may hydraulically overload your Fusion® system and reduce its treatment efficiency. Excessive water use may also overload your soil absorption field and cause failure.

HIGH USE WATER DEVICES

The draining of hot tubs and swimming pools into your Fusion® system could cause hydraulic overloading and may reduce the treatment efficiency. Please drain these devices to another location. Contact your local regulatory authorities or authorized Fusion® maintenance provider for more information. The use of large capacity single fill and drain whirlpool bathtubs may also cause hydraulic overloading of your Fusion®. Please limit the use of these types of tubs.

SYSTEM MAINTENANCE

The Fusion® system is designed to continuously operate automatically with little direct maintenance from the owner. Periodically, a check of the blower area is recommended to ensure no debris obstructs the ventilation or intake areas of the blower. Also, periodically test the control panel as outlined under the control panel section. The owner should closely monitor the types and amounts of substances and products used. Water use should also be closely monitored to ensure proper operation of the Fusion® system.

Periodically, excessive solids will need to be removed from the Fusion® and septic tank (if present) for optimal performance. Your authorized Fusion® maintenance provider will oversee this service. If you should have any questions or need assistance, please contact your maintenance provider. The name of the maintenance provider can be recorded on the front of this document and should also be located on the alarm control panel.

SYSTEM PERFORMANCE

Excessive Foaming

You may see foaming during startup. This is normal and should disappear after a short period of time. It is normally a tan color and is caused by the rapid growth of bacteria. If you see white foam, you may be using too much detergent. Please follow the manufacturer's recommendations. You may also wish to change to another brand of detergent if reduced foaming does not occur within one week. If foaming persists, please contact your authorized Fusion® maintenance provider.

Odor Evaluation

There should be no odors from your Fusion® system because the access riser lids are sealed with a gasket. If you experience any odors, please check the lids to make sure they are screwed down tightly. During normal operation, the Fusion® will have a "musty earth" odor, which should not be offensive. If you experience foul odors, please contact your authorized Fusion® maintenance provider.

Turbidity (Visual Effluent Evaluation)

The Fusion® should produce very clear effluent at the outlet end of the system. If less than clear effluent is being produced, please contact your authorized Fusion® maintenance provider.

NSF INITIAL SERVICE POLICY

The Fusion® models ZF-450, ZF-600, and ZF-800 (NSF Standard 40, Class I certified systems) have a two year service policy included in the initial purchase price. The service policy will include two inspections per year for a total of four inspections. During these inspections, the effluent quality from the Fusion® shall be evaluated for color, turbidity, scum overflow and odor. Please check the identification plate on the blower housing or the control panel to locate your maintenance provider's name and phone number.

Should there be any operational deficiencies with your Fusion®, the maintenance provider will notify the owner in writing when the deficiencies will be corrected. If the maintenance provider does not correct the deficiencies or the service calls are not completed, please contact Clarus Environmental at 1-877-244-9340.

The owner should only perform minimal routine maintenance on the Fusion® such as clearing debris from around blower housing (leaves, snow, and grass clippings). The Fusion® should also be protected from excessive weight such as vehicular traffic. Trees and bushes should not be planted in close proximity to the Fusion®. The Fusion® should be accessible to maintenance personnel and the riser lids must never be buried.

Fusion® AUTHORIZED MAINTENANCE PROVIDER INSPECTIONS

Your authorized maintenance provider will perform many system checks and adjustments as needed during the maintenance inspection. Two inspections per year will be made for a total of four inspections during the initial service policy. The blower will be checked for proper operation and the blower air filter will be cleaned or changed. The control panel will be inspected for proper operation during the inspection. The maintenance provider will also measure the amount of solids in the Fusion® and the septic tank (if present) to determine when the solids must be removed. Standard maintenance for the Fusion® includes pumping of the sedimentation and anaerobic chambers as needed. See Operation and Maintenance Manual (CL0301J) and Installation Instructions (CL0301D) for further information.

EXTENDED MAINTENANCE POLICY

An extended maintenance policy is available for purchase from your authorized Fusion® distributor. The extended maintenance policy will include the same system checks, schedule, and adjustments as the initial maintenance policy. Please contact your Fusion® distributor or maintenance provider for further information regarding the extended maintenance policy.

ALARM CONDITION

If an alarm condition occurs, please check the air intake area around the blower and make sure no debris blocks the blower intake. Do not attempt to remove the blower housing or any other parts from the blower. If the blower is operating properly, there may be a high water condition within the Fusion®. It may be necessary to discontinue water use until the alarm condition has been resolved. If the buzzer continues to sound or the red light stays on, please contact your authorized Fusion® maintenance provider. The buzzer may be silenced by toggling the black switch on the side of the alarm panel to "silence". The red beacon light will remain on until the problem has been resolved.

Check the circuit breaker and make sure the blower circuit is on. Reset the breaker switch if it has been tripped. If it continues to trip or the alarm continues to remain on, contact your Fusion® maintenance provider.

You may from time to time check the proper operation of the alarm panel by toggling the black switch on the side of the panel to "test". The buzzer will sound and the red beacon will light as long as you hold the switch in the test position. Release the switch for normal operation.

POWER OUTAGE

Should you experience a power outage, the blower will not operate and air (oxygen) will not be supplied to the Fusion®. If the blower is off for more than 48-72 hours, the lack of fresh air will cause the treatment efficiency to decrease. During a power outage, the Fusion® will still allow effluent to flow, and will not create a backup in the home. You may, however, have a pump or dose tank with a pump on the outlet of the Fusion®, which requires power to pump the effluent to the soil absorption field. If you have a system such as this, please be aware of this condition and conserve water accordingly.

FLOODING

If flooding of the Fusion® occurs and the blower or the control panel is submerged, please disconnect power at the circuit breaker. DO NOT try to reconnect power to either the blower or alarm control panel once it has been submerged. Immediately contact your authorized Fusion® maintenance provider to inspect the Fusion®, the blower, and the control panel. Your maintenance provider will repair the components as needed.

INTERMITTENT USE

The Fusion® system is designed to function even if wastewater does not enter it for extended periods of time. The power to the blower must remain on during this time for the system to function properly. Weekend use will not harm the system as long as the blower is on. Should seasonal use require a complete shut down of the property, then it is recommended that the blower be turned off. It is important to start up the system in advance of actual occupancy to allow for normal treatment to resume. Please contact your authorized Fusion® maintenance provider for further information concerning shut down and startup of the Fusion®. You may also contact your maintenance provider for the shut down and startup services.

LIMITED WARRANTY

Manufacturer warrants, to the purchaser and subsequent owner during the warranty period, every new product to be free from defects in material and workmanship under normal use and service, when properly used and maintained, for a period of two years from date of installation. Parts that fail within the warranty period, two years from date of installation, that inspections determine to be defective in material or workmanship, will be repaired, replaced or remanufactured at manufacturer's option, provided however, that by so doing we will not be obligated to replace an entire assembly, the entire mechanism or the complete unit. No allowance will be made for shipping charges, damages, labor or other charges that may occur due to product failure, repair or replacement.

This warranty does not apply to and there shall be no warranty for any material or product that has been disassembled without prior approval of manufacturer, subjected to misuse, misapplication, neglect, alteration, accident or act of God; that has not been installed, operated or maintained in accordance with manufacturer's installation instructions; that has been exposed to outside substances including but not limited to the following: sand, gravel, cement, mud, tar, hydrocarbons, hydrocarbon derivatives (oil, gasoline, solvents, etc.), or other abrasive or corrosive substances, wash towels or feminine sanitary products, etc. in all applications other than in raw sewage pumping applications. The warranty set out in the paragraph above is in lieu of

all other warranties expressed or implied; and we do not authorize any representative or other person to assume for us any other liability in connection with our products.

Contact manufacturer at, 3649 Cane Run Road, Louisville, Kentucky 40211, Attention: Customer Service Department to obtain any needed repair or replacement of part(s) or additional information pertaining to our warranty.

MANUFACTURER EXPRESSLY DISCLAIMS LIABILITY FOR SPECIAL, CONSEQUENTIAL OR INCIDENTAL DAMAGES OR BREACH OF EXPRESSED OR IMPLIED WARRANTY; AND ANY IMPLIED WARRANTY OF FITNESS FOR A PARTICULAR PURPOSE AND OF MERCHANTABILITY SHALL BE LIMITED TO THE DURATION OF THE EXPRESSED WARRANTY.

Some states do not allow limitations on the duration of an implied warranty, so the above limitation may not apply to you. Some states do not allow the exclusion or limitation of incidental or consequential damages, so the above limitation or exclusion may not apply to you.

This warranty gives you specific legal rights and you may also have other rights which vary from state to state.

TYPICAL Fusion® INSTALLATION

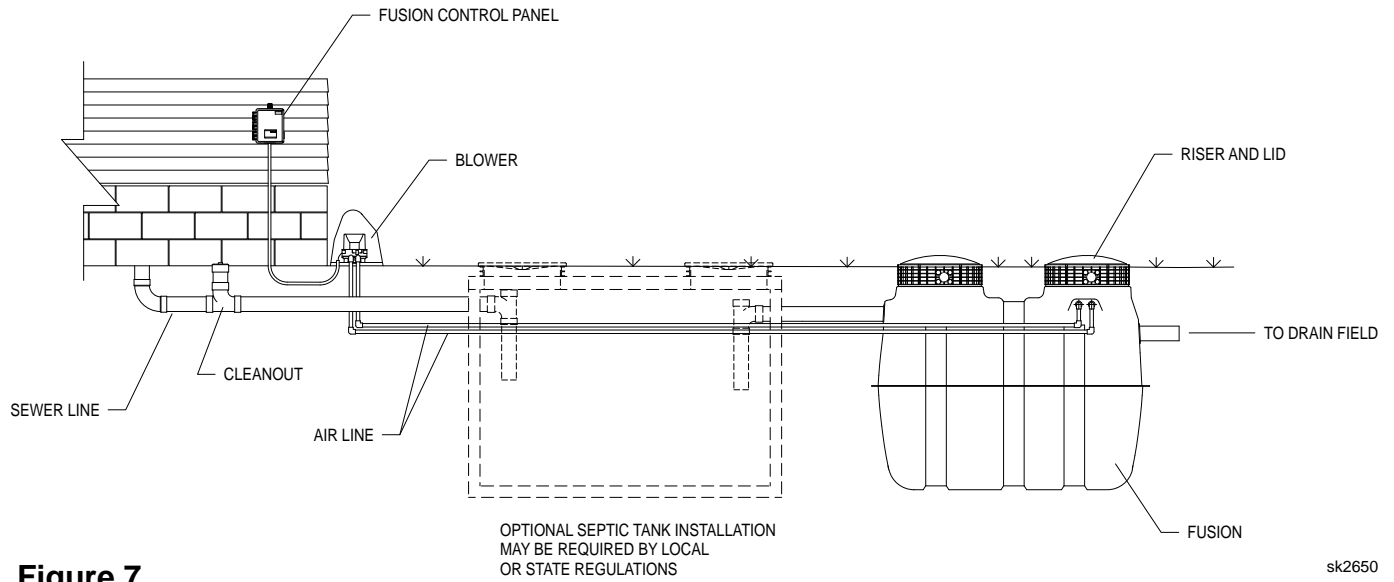

Figure 7

sk2650

All Clarus Environmental products must be installed and maintained in accordance with all applicable codes. Product information presented here reflects conditions at time of publication. Consult factory regarding discrepancies or inconsistencies.

© Copyright 2010. All rights reserved.