

DRAWING NOT FOR CONSTRUCTION USE  
UNLESS STAMPED CERTIFIED BY WATER  
SERVICES INC.

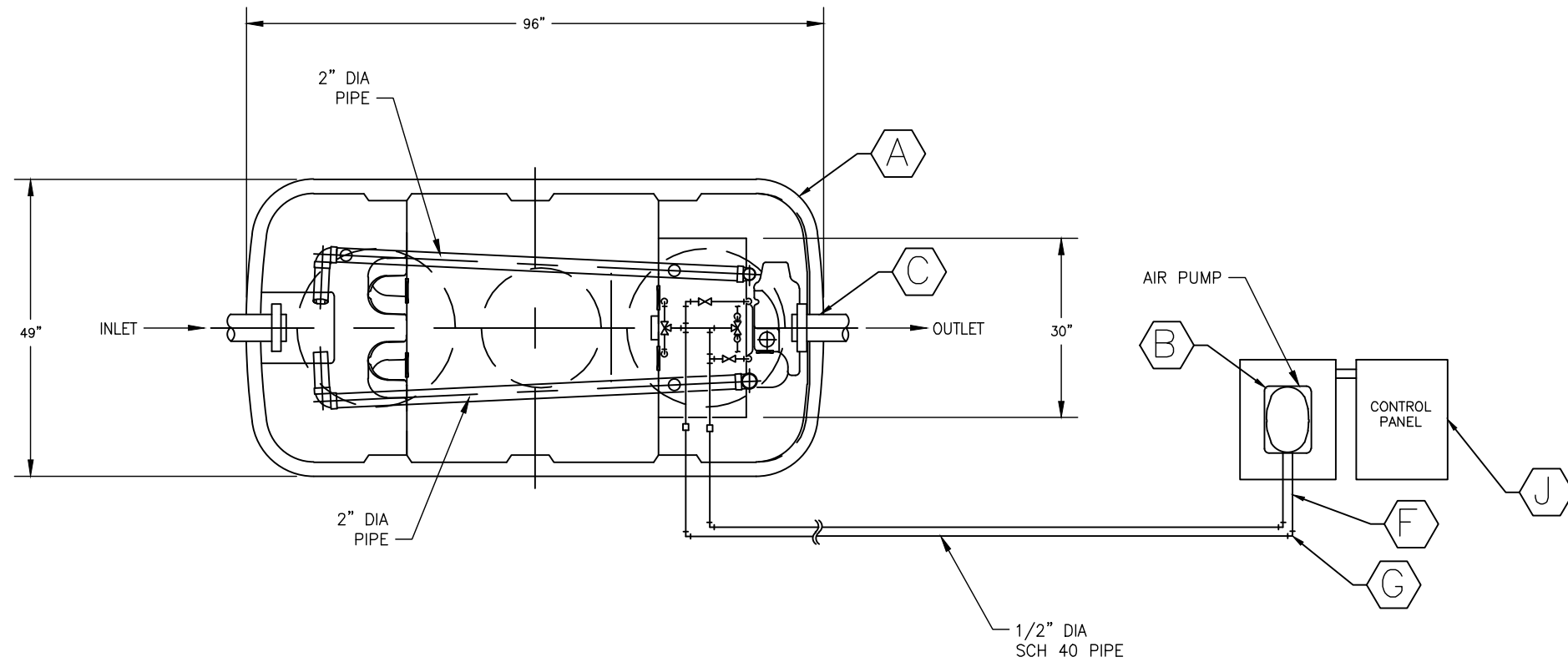

SYM.	DISCRIPTION	QTY.
(A)	ZF-450 FUSION UNIT	2
(B)	AIR PUMP (Blower)	2
(C)	10ft 4" PVC PIPE	2
(D)	4" 90° PVC FITTING	0
(E)	4" TEE PVC FITTING	0
(F)	10ft 1/2" PVC PIPE	2
(G)	1/2" 90° PVC FITTING	4
(H)	10ft 3/4" PVC PIPE	0
(I)	3/4" 90° PVC FITTING	0
(J)	CONTROL PANEL	1

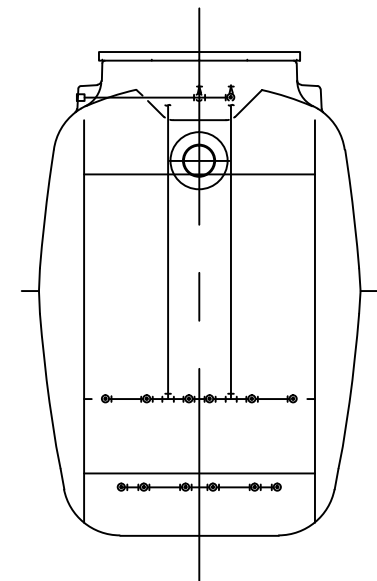
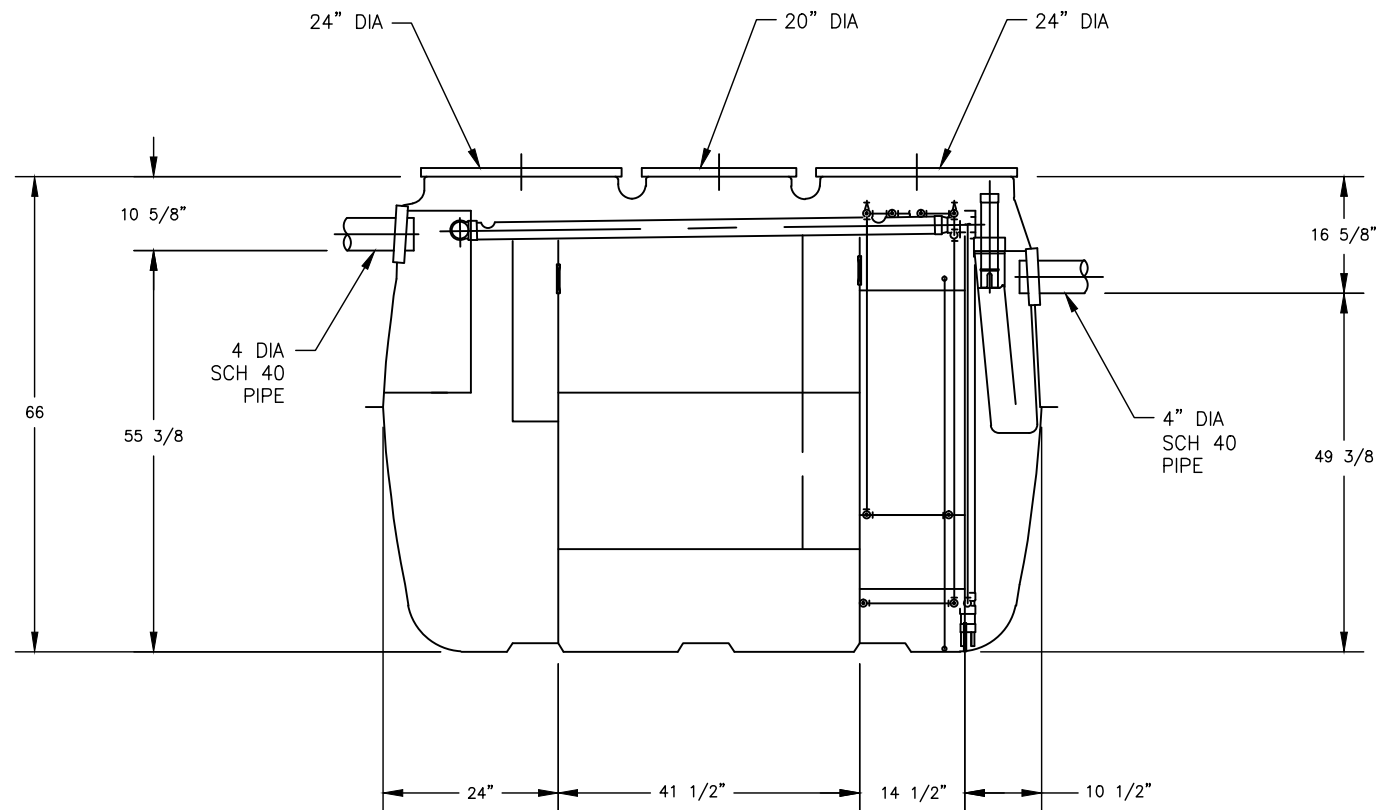

UNCONTROLLED  
COPY

**NOTICE:**  
THIS DRAWING HAS NOT BEEN PUBLISHED AND IS THE SOLE PROPERTY OF WATER SERVICES, INC. IT IS LENT TO THE BORROWER FOR HIS CONFIDENTIAL USE ONLY. IN CONSIDERATION OF THIS LOAN, THE BORROWER PROMISES TO RETURN IT UPON REQUEST AND AGREES THAT IT SHALL NOT BE REPRODUCED, COPIED, LENT, OR OTHERWISE DISPOSED OF, DIRECTLY OR INDIRECTLY, NOR USED FOR ANY PURPOSE OTHER THAN THAT FOR WHICH IT IS SPECIFICALLY FURNISHED.

**TOLERANCE UNLESS NOTED:**  
ALL DIMENSIONS IN INCHES  
DIMENSIONS IN [ ] = METRIC  
BREAK ALL SHARP EDGES  
CONNECTION POINTS = ± 1/4"  
ANGLES = ± 1°  
NON-FUNCTIONAL DIM'S = ± 1"

DRAWN	K S	DATE	
CHECKED	XXXXXX	DATE	
APPROVED	XXXXXX	DATE	
NEXT ASS'Y	XXXXXX	WEIGHT	



Water Services Inc.  
372 S. 900 W. Provo, Utah 84601  
Phone: +1-801-705-4567  
FAX: +1-801-221-2587

TITLE: WSI-F-600  
SCALE: \_\_\_\_\_ DWG. NO. #1  
CUSTOMER: CUST  
REV: R